

英

# INSTRUCTION BOOK

RIBBER CARRIAGE  
RJ1

# CONTENTS

	page
RIBBER CARRIAGE .....	1
OPERATION TABLE	
Punch Card Knitter .....	3
Electronic Knitter .....	4
DOUBLE JACQUARD	
Punch Card Knitter .....	6
Punching a Card for Double Jacquard .....	7
Electronic Knitter .....	10
To change pattern while knitting Double Jacquard .....	12
To knit Single Motif in Double Jacquard .....	12
To knit Double Jacquard using Switch 3 .....	12
To knit Double Rib which looks the same as Double Jacquard .....	12
If incorrectly knitted in the course of Double Jacquard .....	12
If incorrectly knitted in the course of Double Jacquard using Switch 3 .....	12
MULTI COLOURED JACQUARD .....	13
HINTS WHEN KNITTING DOUBLE JACQUARD AND MULTI COLOURED JACQUARD .....	15

## RIBBER CARRIAGE

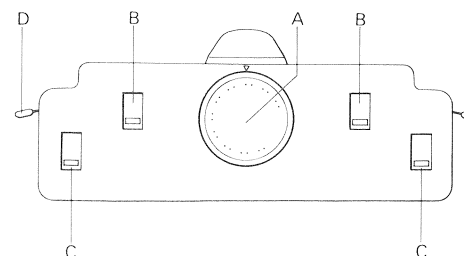

- A — Stitch Dial
- B — Set Levers
- C — Select Levers
- D — Russel Levers

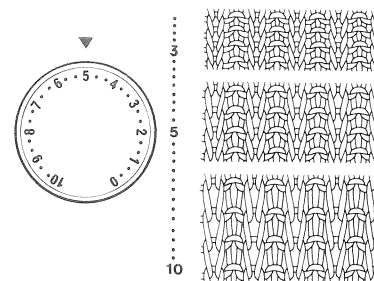

### Stitch Dial

Controls stitch size.  
Set a selected number or dot to ▽ mark.  
The larger the number the bigger the stitch, and the smaller the number the smaller the stitch.  
According to the thickness of yarn to be used, select proper setting of Stitch Dial.

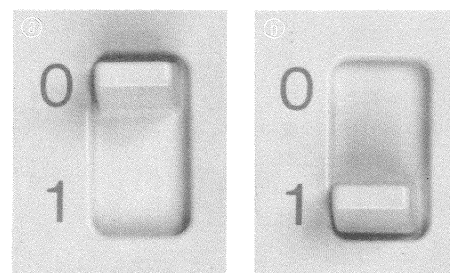

### Set Levers

Control needles in "B" position.  
 (a) NON KNITTING POSITION, needles in B position will not knit.  
 (b) KNITTING POSITION, needles in B position will knit.  
 Left Lever works when the Carriage moves to the left.  
 Right Lever works when the Carriage moves to the right.

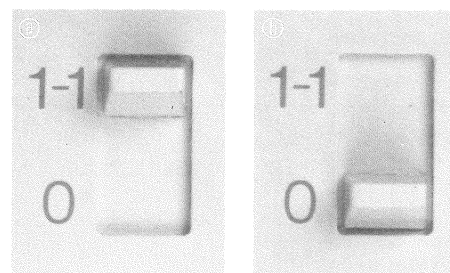

### Select Levers

Used to knit Double Jacquard or Multi Coloured Jacquard.  
 (a) 1-1.....Every alternate needle knits Slip Stitch  
 (b) 0.....Every needle knits Stockinet  
 Left Lever works when the Carriage moves to the left.  
 Right Lever works when the Carriage moves to the right.

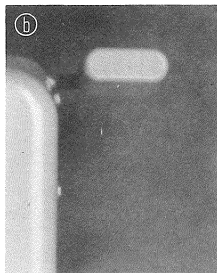
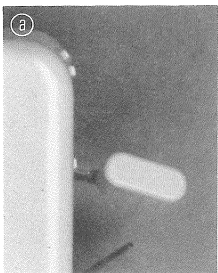

### Russel Levers

Control needles in "D" position.

- Ⓐ NON KNITTING POSITION, needles remain in D position.
- Ⓑ KNITTING POSITION, needles in D position will knit back to B position.

Left Lever works when the Carriage moves to the left.  
Right Lever works when the Carriage moves to the right.

## OPERATION TABLE

For Cast-on and main knitting, Operation Table gives settings and operation of machine.

### PUNCH CARD KNITTER

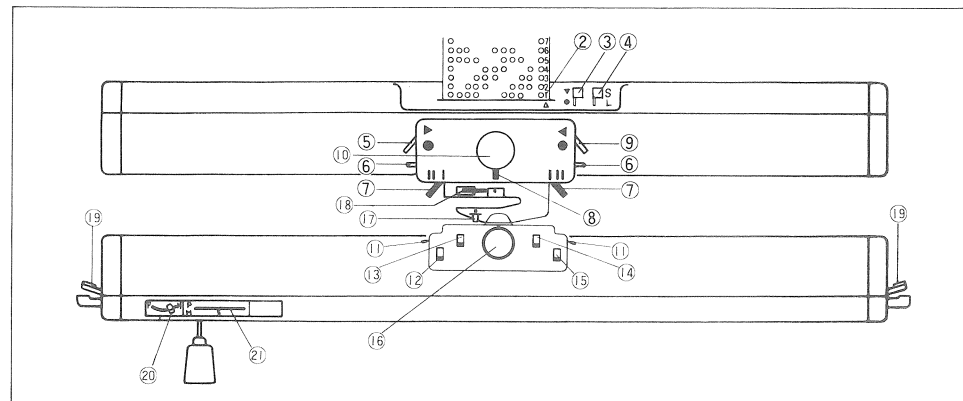

	①	Procedural order of the Operation Table	
PATTERN PANEL	②	Pattern Row Number	↓ — Set the Punch Card and lock at 1
	③	Stop Knob	
	④	L Knob	
	⑤	Side Lever (left)	
KNITTER CARRIAGE	⑥	Intarsia Levers (left & right)	Always set at 1 when using Ribber
	⑦	Russel Levers (left & right)	Always set at III, except when partial knitting
	⑧	Cam Lever	
	⑨	Side Lever (right)	
	⑩	Stitch Dial	
RIBBER CARRIAGE	⑪	Russel Levers (left & right)	Always set at =, except when partial knitting
	⑫	Select Lever (left)	
	⑬	Set Lever (left)	
	⑭	Set Lever (right)	
	⑮	Select Lever (right)	
	⑯	Stitch Dial	
RIBBER ARM	⑰	Auxiliary Yarn Feeder Lever	
	⑱	Driving Lever	→ — resting position ↑ — working position
RIBBER NEEDLE BED	⑲	Pile Levers (left & right)	↑ — upper position ↓ — lower position
	⑳	Half-Pitch Lever	
	㉑	Swing Indicator	
	㉒	Arrow mark indicates knitting direction of Carriage and number shows the number of rows required to be knitted.	

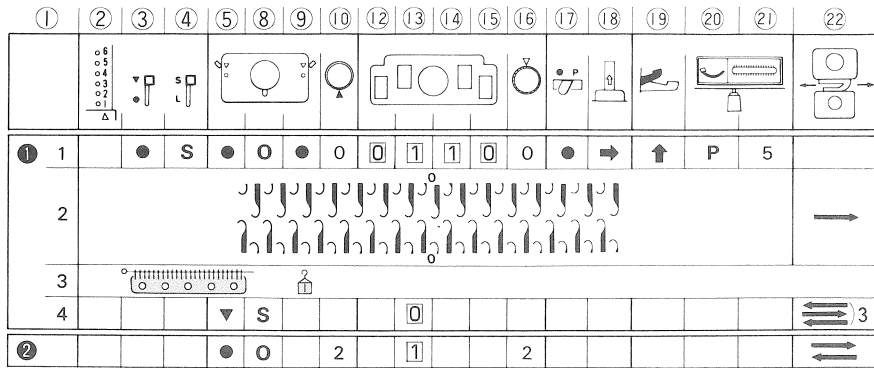

**ELECTRONIC KNITTER**

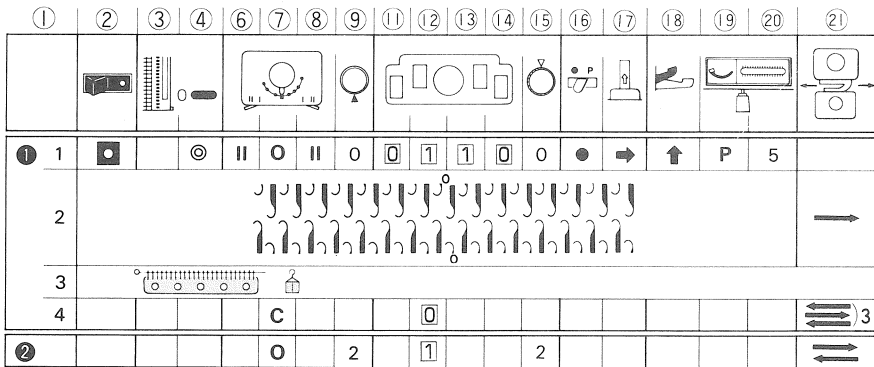
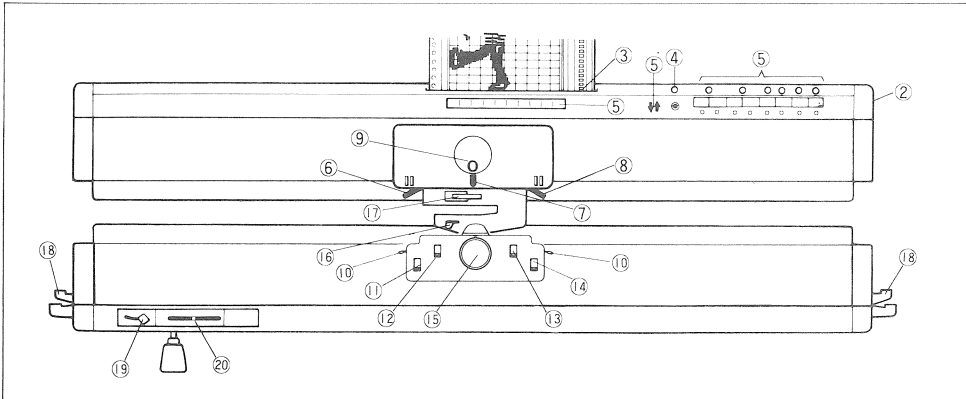

	①	Procedural order of the Operation Table	
	②	ON-OFF Switch	■ — Turn ON the machine
PATTERN PANEL	③	Pattern Row Number	↓ — Set the Pattern Card
	④	Inspection Switch	● — Light is ON ○ — Light is OFF
KNITTER CARRIAGE	⑤	Pattern Controls	Set Pattern Controls (Pattern Width, Direction Switch and Pattern Switches) as instructed.
	⑥	Russel Lever (left)	
	⑦	Cam Lever	
	⑧	Russel Lever (right)	
RIBBER CARRIAGE	⑨	Stitch Dial	
	⑩	Russel Lever (left & right)	Always set at =, except when partial knitting.
	⑪	Select Lever (left)	
	⑫	Set Lever (left)	
	⑬	Set Lever (right)	
	⑭	Select Lever (right)	
RIBBER ARM	⑮	Stitch Dial	
	⑯	Auxiliary Yarn Feeder Lever	
RIBBER NEEDLE BED	⑰	Driving Lever	→ — resting position ↑ — working position
	⑱	Pile Levers (left & right)	↑ — upper position ↓ — lower position
	⑲	Half-Pitch Lever	
	⑳	Swing Indicator	
	㉑	Arrow mark indicates knitting direction of Carriage and number shows the number of rows required to be knit.	

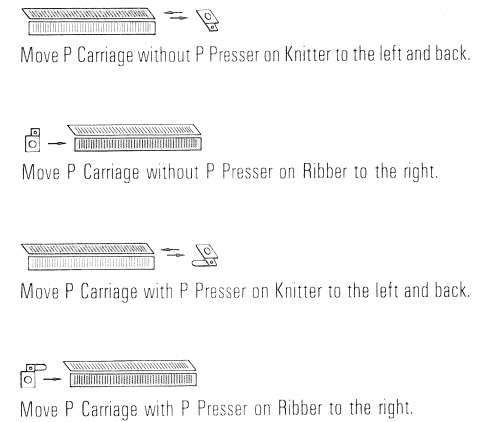
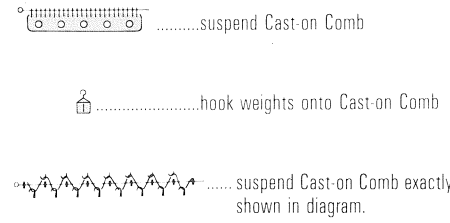
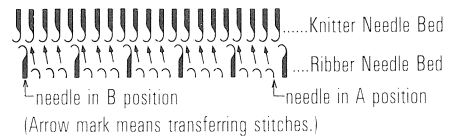



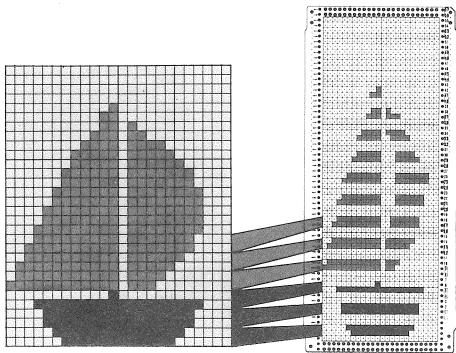

- (2) Mark the parts of contrast yarn on the first and second rows of the pattern onto the second and third rows of the Card (non-coloured rows) respectively.

In the same manner mark the parts of contrast yarn of every 2 rows of the pattern onto non-coloured rows of the Card.

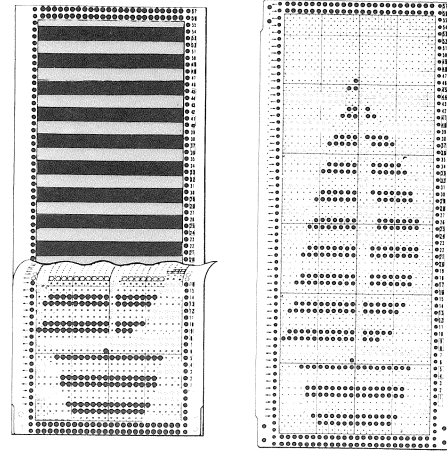

5. To check that the card is correctly punched, lay it over Check Card.

*Make sure that the edges of punched card match the Check Card.*

Punched holes in orange colour.....background yarn  
Punched holes in blue colour.....contrast yarn

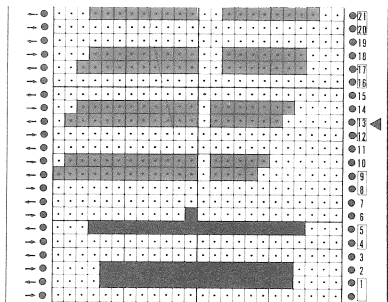
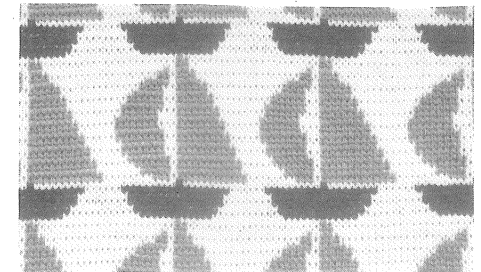

- (3) If more than two yarns are to be used for the pattern, mark the position to change the yarn (at the odd row number).

*The row number to appear at the Pattern Panel while knitting corresponds to the row of five rows below.*

*Holder button for the yarn to be selected next is pushed when the Carriage is at right side, so the yarn changing mark must be positioned one row before the yarn is knitted.*

3. Punch the sections marked.

6  
5  
4  
3  
2  
1

Row numbers rectangled . . . . . Knit with background yarn.

Row numbers not rectangled . . . . . Knit with contrast yarn.

Extra Pre-Punched Card sets for Double Jacquard (Series 73 & 74) are also available.

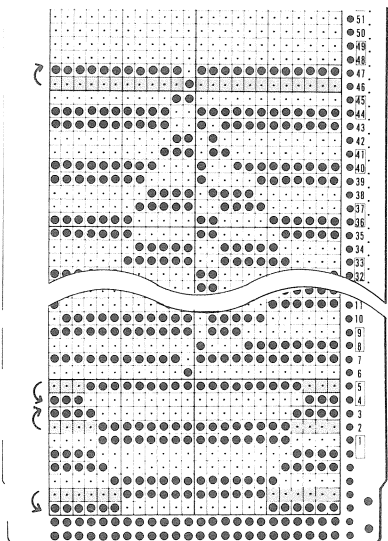

4. Punch the sections for background yarn which correspond to the non-punched sections of the pattern rows in the following manner.

- (1) For the first row, punch the sections which correspond to the non-punched sections on the second row.

- (2) Of the two consecutive coloured rows of the NP Card, punch the lower row to match the non-punched section of the row below, and punch the upper row to match the non-punched section of the row above.

- (3) The last row of punching must be for the background yarn so that it matches the first row punched on the card.







## Cast-On

- ① — 1~4 Set machine controls, arrange needles as instructed, and work cast on.
- 5 Change machine controls and knit 2 rows.
- 6 Hook contrast yarn on Holder B and C respectively.  
Press Switch 3 so the light comes on.

## Main Knitting

- ② — 1 Press Inspection Switch so the light comes off.  
Set Cam Lever to "S" (SLIP).  
Set Driving Lever to upright position.  
Set Select Levers to **[1-1]** and Set Levers to **[0]**  
Knit 1 row from the left to the right.  
Bring Holder A to ② position and Holder B to ① position.
- 2 Knit 1 row from the right to the left.  
Make sure that the Driving Lever operates Feeding Lever and the yarn in the Main Yarn Feeder is exchanged for the yarn in Holder B.
- 3 Knit 1 row from the left to the right and bring Holder C to ① position.
- 4 Knit 1 row from the right to the left.
- 5 Knit 1 row from the left to the right and bring Holder A to ① position.
- 6 Knit 1 row from the right to the left and repeat steps ② — 1~6.

## HINTS WHEN KNITTING DOUBLE JACQUARD AND MULTI COLOURED JACQUARD

### Select Levers

These are the additional mechanisms used to knit Double Jacquard and Multi Coloured Jacquard.

\* By setting Select Levers to **[1-1]** and Set Levers to **[0]**, every alternate needle knits Slip Stitch on the Ribber and stripes of one row will be formed on the wrong side of the fabric.

\* By setting Select Levers to **[0]** and Set Levers to **[1]**, every needle knits Stockinet on the Ribber and stripes of two rows will be formed on the wrong side of the fabric.

Be sure to have an even number of needles in working position on the Ribber at all times because every alternate needle, starting with the first needle nearest to the Carriage, knits Slip Stitch.

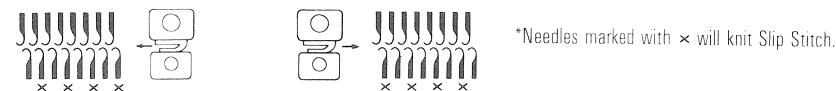

If an odd number of needles are in working position on the Ribber, the same needles will knit Slip Stitch every row.



### Decreasing stitches at the edge

#### To decrease one stitch at both edges.

- 1- On the Ribber, transfer two stitches onto the adjacent needles at the side where the ribber needle lies to the outside of the knitter needle and push the empty needles back to A position.



N.B. Always decrease two stitches at one side instead of decreasing one stitch at each side.

- 2- On the Knitter, transfer both edge stitches onto their adjacent needles and push the empty needles back to A position.



#### To decrease several stitches at the edge.

You can decrease only on the Carriage side.

- 1- Set Half Pitch Lever to P.
- 2- Transfer the required even number of ribber stitches to their corresponding knitter needles.  
N.B. If an odd number of stitches are required to be decreased, subtract or add one stitch to make the total decreased stitches an even number.
- 3- Cast off the required number of stitches to be decreased, using the yarn.
- 4- Set Half Pitch Lever to H to continue knitting.

### Increasing stitches at the edge

#### To increase one stitch at both edges.

1- On the Ribber, push two empty needles from A to B position at the side where the knitter needle lies to the outside of the ribber needle.



N.B. Always increase two stitches at one side instead of increasing one stitch at each side.

2- On the knitter, push one empty needle from A to B position at each side.

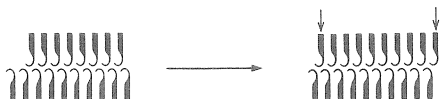

#### To increase several stitches at the edge.

You can increase on the opposite side of the Carriage.

1- On the Knitter, push the required number of needles to B position.

2- On the Ribber, push the required even number of needles to B position.

N.B. If an odd number of stitches are required to be increased, subtract or add one stitch to make the total increased stitches an even number.

3- Knit one row.

4- Hang Edge Weight and continue to knit.

### Partial Knitting

#### To decrease stitches.

\* Follow the instructions given in the instruction book of Ribbing Attachment, provided that an even number of needles must be pushed to D position on the Ribber.

#### To increase stitches

\* Follow the instructions given in the instruction book of Ribbing Attachment, provided that an even number of needles must be pushed back to B position on the Ribber.

### Recommended Stitch Dial settings for each type of yarn

	thin yarn	light yarn	medium yarn
Knitter	2 — 4	4 — 6	7 — 8
Ribber	2 — 4	4 — 6	7 — 8

\*For cast-on, refer to the Stitch Dial settings for Double Rib instructed in the instruction book of Ribbing Attachment.

© Silver Seiko Ltd. 1989

All rights reserved.

Reproduction in whole or in part without written permission is prohibited.